

Single impeller centrifugal pumps with hydraulic components manufactured from stainless steel AISI 304, suitable for pressure boosting, water supply, treatment & irrigation. Air conditioning systems and general water pumping including moderately aggressive liquids



SPECIFICATIONS

- Maximum working pressure: 8 bar
- Maximum liquid temperature:
35°C according EN 60335-2-41 for domestic uses
60°C for other uses of CDX 70/05-70/07-90/10
90°C for other models
110° for H version

MATERIALS

- Pump body, impeller, diffuser and casing cover in AISI 304
- Shaft in AISI 303
- Bracket and motor casing in alluminium
- Mechanical seal in carbon/ceramic/NBR
- Special mechanical seal are available on demand

TECHNICAL DATA

- T.E.F.C. 2 poles motor
- Insulation class F
- Protection degree IP55
- 1~230V ± 10% 50Hz, 3~230/400V ± 10% 50Hz
- Permanent split capacitor and automatic thermal overload protection for single-phase version
- Thermal protection to be provided by the user for three-phase version
- DNA 1^{3/4} for CDX200, DNA 1^{1/4} for the other models
- DNM 1"

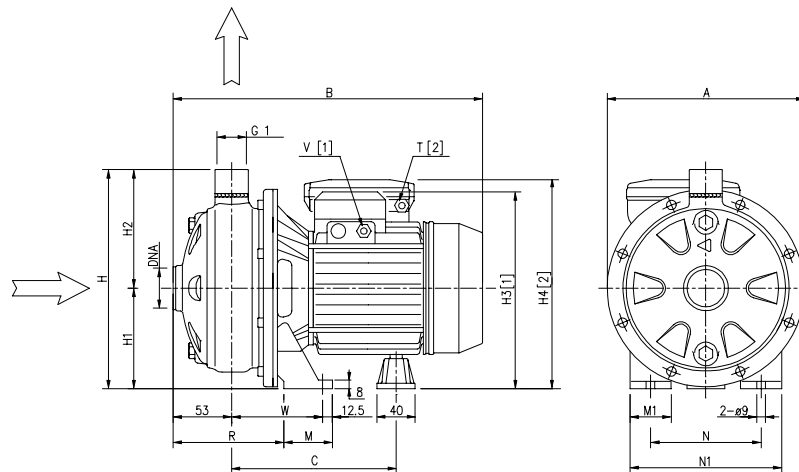

DIMENSIONAL TABLE

Pump type		Dimensions (mm)														Weight kg					
		A	B		C	H	H1	H2	H3	H4	M	M1	N	N1	R	T	W	DNA	Single-phase	Three-phase	
Single-phase	Three-phase		1~	3~																	
CDXM 70/05	CDX 70/05	208	318	318	178	229,5	106	123,5	209	215	50	38	120	160	108	PG11	92,5	G 1 1/4	9,1	9,1	
CDXM 70/07	CDX 70/07	208	318	318	178	229,5	106	123,5	209	215	50	38	120	160	108	PG11	92,5	G 1 1/4	10,4	10,4	
CDXM 90/10	CDX 90/10	208	318	318	178	229,5	106	123,5	209	215	50	38	120	160	108	PG11	92,5	G 1 1/4	11,9	11,9	
CDXM 120/07	CDX 120/07	208	318	318	178	229,5	106	123,5	209	215	50	38	120	160	108	PG11	92,5	G 1 1/4	10,4	10,4	
CDXM 120/12	CDX 120/12	208	318	318	178	229,5	106	123,5	209	215	50	38	120	160	108	PG13,5	92,5	G 1 1/4	12,5	12,5	
CDXM 120/20	CDX 120/20	232	345	345	199	250	118	132	235	253	55	40	140	180	105,5	PG13,5	95	G 1 1/4	17,2	16,2	
CDXM 200/12	CDX 200/12	208	318	318	178	229,5	106	123,5	209	215	50	38	120	160	108	PG13,5	92,5	G 1 1/2	16,3	11,4	
CDXM 200/20	CDX 200/20	208	345	345	199	229,5	106	123,5	223	240	55	40	140	180	105,5	PG13,5	95	G 1 1/2	15,3	14,2	
	CDX 200/25	232	-	345	199	250	118	132	235	-	55	40	140	180	105,5	-	95	G 1 1/2	-	17	

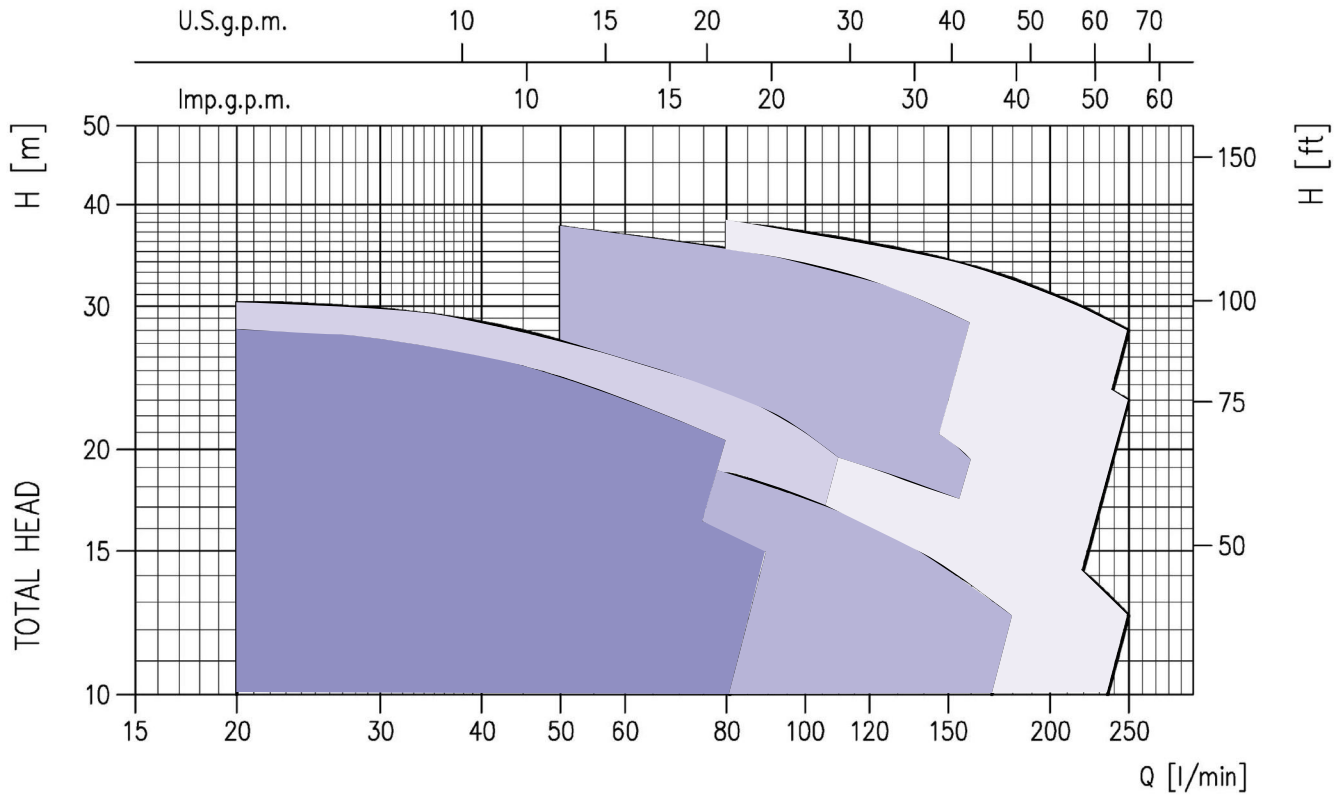
PERFORMANCE CHART (according to ISO 9906 Annex A)

PERFORMANCE TABLE

Pump type		kW	Capacitor		Absorbed Current (A)			Q=Capacity l/min	H=Total head									
Single-phase 230V 50Hz	Three-phase 230/400V 50Hz		μF	V _c	Single-phase	Three-phase 230V 400V			20	50	80	90	110	130	160	180	210	250
CDXM 70/05	CDX 70/05	0,37	12,5	450	3,1	2,4	1,4	20,7	18,4	15,9	15	-	-	-	-	-	-	
CDXM 70/07	CDX 70/07	0,55	16	450	4,6	3,5	2,0	28	24,5	20,5	-	-	-	-	-	-	-	
CDXM 90/10	CDX 90/10	0,75	20	450	5,6	4,0	2,3	30,3	27,2	23,6	22,3	19,5	-	-	-	-	-	
CDXM 120/07	CDX 120/07	0,55	16	450	4,6	3,2	1,9	-	20,5	18,7	18,1	16,8	15,5	13,7	12,5	-	-	
CDXM 120/12	CDX 120/12	0,9	31,5	450	6,9	5,2	3,0	-	29,5	27,1	26,1	24,3	22,4	19,5	-	-	-	
CDXM 120/20	CDX 120/20	1,5	40	450	9,3	7,0	4,0	-	37,5	35,3	34,6	33,1	31,4	28,6	-	-	-	
CDXM 200/12	CDX 200/12	0,9	31,5	450	6,3	4,7	2,7	-	-	20,6	20,2	19,5	18,5	17,1	16,1	14,6	12,5	
CDXM 200/20	CDX 200/20	1,5	40	450	10,7	7,0	4,0	-	-	31	30,6	29,7	28,9	27,5	26,6	25,1	23	
	CDX 200/25	1,8	-	-	-	8,2	4,8	-	-	38	37,5	36,4	35,3	33,6	32,4	30,5	28	

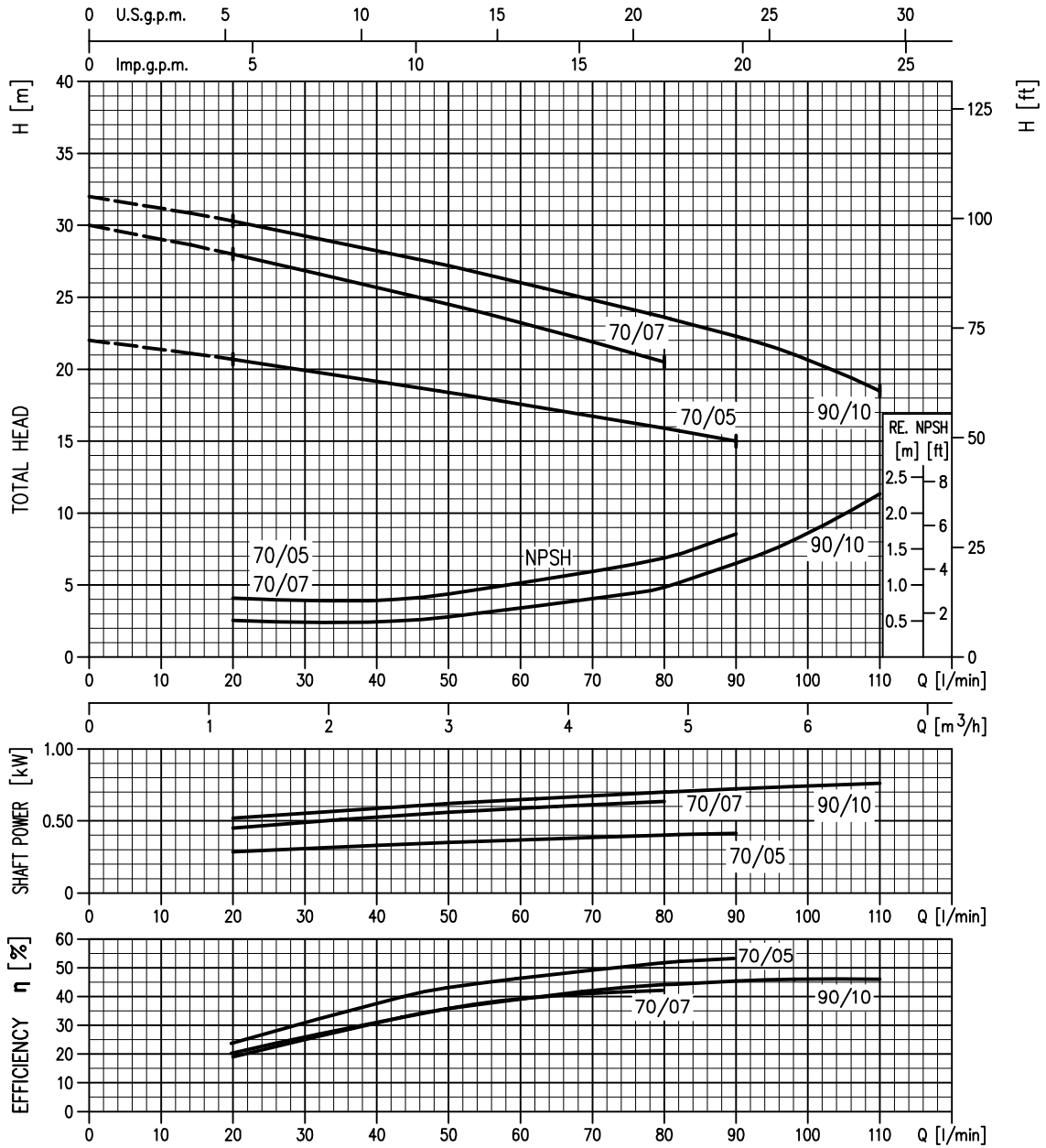
PERFORMANCE CURVES CDX 70-90 series (according to ISO 9906 Annex A)

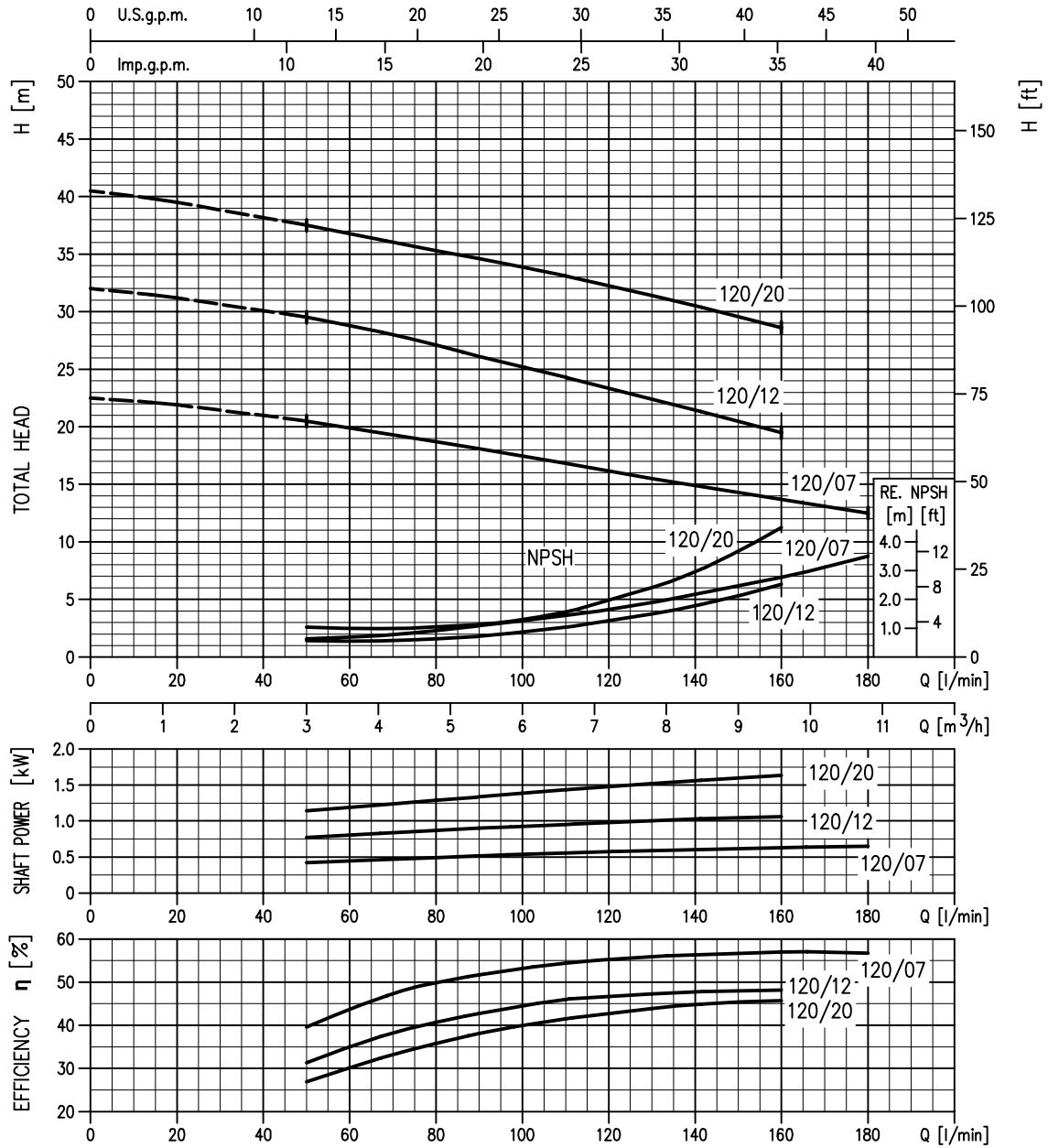

PERFORMANCE CURVES CDX 120 series (according to ISO 9906 Annex A)



PERFORMANCE CURVES CDX 200 series (according to ISO 9906 Annex A)

